

01

Height Adjustable  
Table Frames & Accessories

# E-SMART 1M2S QA



Table frame, electric height adjustable, quick assembly

- Very simple and extremely quick installation thanks to pre-assembled lifting columns and drive shaft
- Five-language control element with 4 memory slots as well as USB-A and USB-C charging
- Integrated collision protection, reminder function for changing position and child safety lock
- 5 years warranty

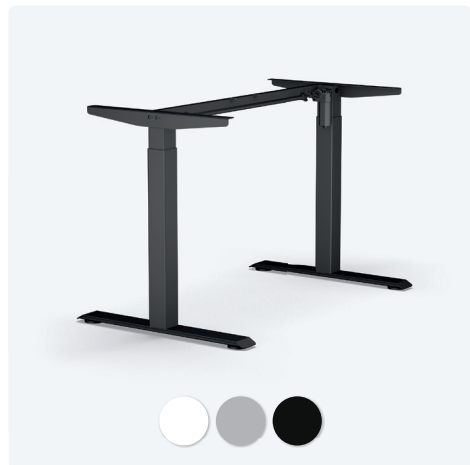

## Details

Motors	1
Lifting column segm.	2
Column cross-section	70x70 mm
Lifting range	700-1170 mm
Frame width	1100-1600 mm
Table top size min	700x1100 mm
Table top size max	1000x1800 mm
Load capacity	80 kg
Memory keys	4
USB charging	USB-A / USB-C / 18 W
Speed	25 mm/s
Anti collision function	integrated (8 level)
Reminder function	integrated
Child lock	integrated
Sound level	<50 dB
Power consumpt. min	0,1 W
Power consumpt. max	70 W
Duty cycle	max 2 min "on" / 18 min "off"

## Technical Drawings

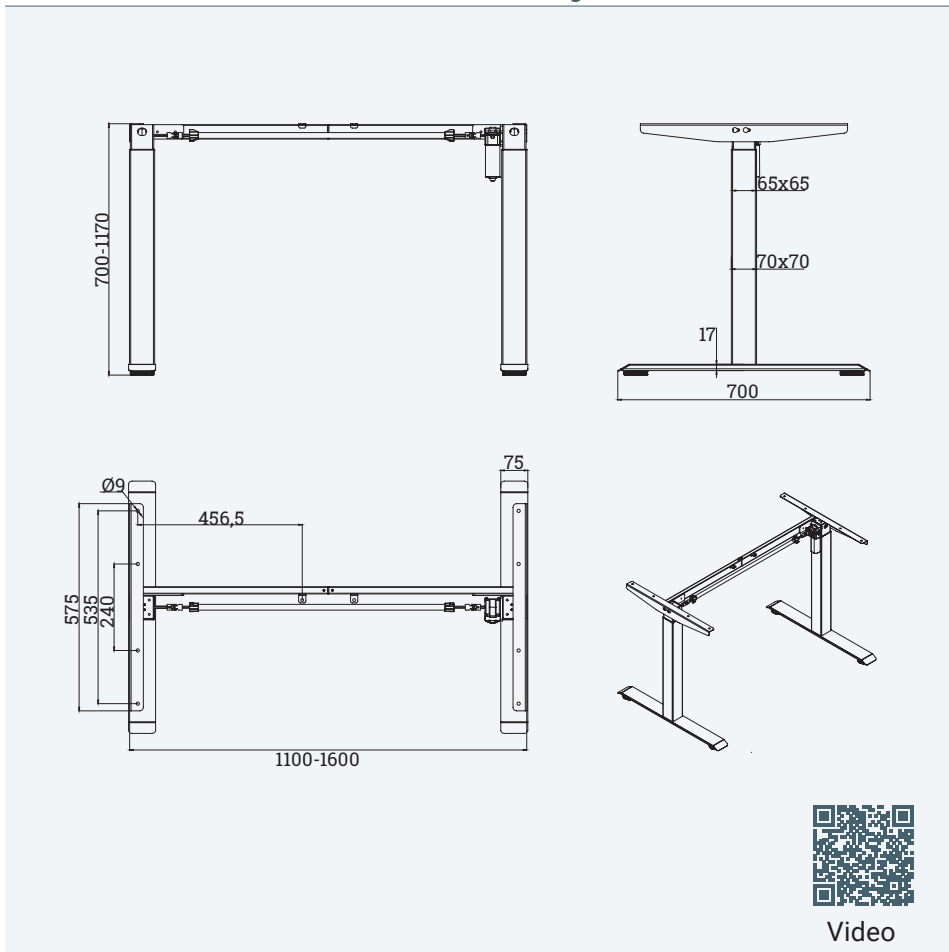

Video

Article	Description	Colour	Item No.
E-SMART 1M2S QA	Electric height adjustable table frame, lifting columns: 70x70 mm, 700-1170 mm, 1 motors, 2 segments, 80 kg, 25 mm/s, quick assembly, 4 memory keys, USB A, USB C, Reminder function	RAL 9017, Traffic black	301 132018
		Aluminium	301 132004
		White	301 132011

# E-SMART 2M2S



Table frame, electric height adjustable

- ✓ 2 motors / 2-stage / double crossbar for high stability
- ✓ Five-language control element with 4 memory slots as well as USB-A and USB-C charging
- ✓ Integrated collision protection, reminder function for changing position and child safety lock
- ✓ 5 years warranty



## Details

Motors	2
Lifting column segm.	2
Column cross-section	70x70 mm
Lifting range	700-1200 mm
Frame width	1100-1600 mm
Table top size min	600x1100 mm
Table top size max	1000x1800 mm
Load capacity	80 kg
Memory keys	4
USB charging	USB-A / USB-C / 18 W
Speed	25 mm/s
Anti collision function	integrated (8 level)
Reminder function	integrated
Child lock	integrated
Sound level	<50 dB
Power consumpt. min	0,1 W
Power consumpt. max	70 W
Duty cycle	max 2 min "on" / 18 min "off"



## Technical drawings

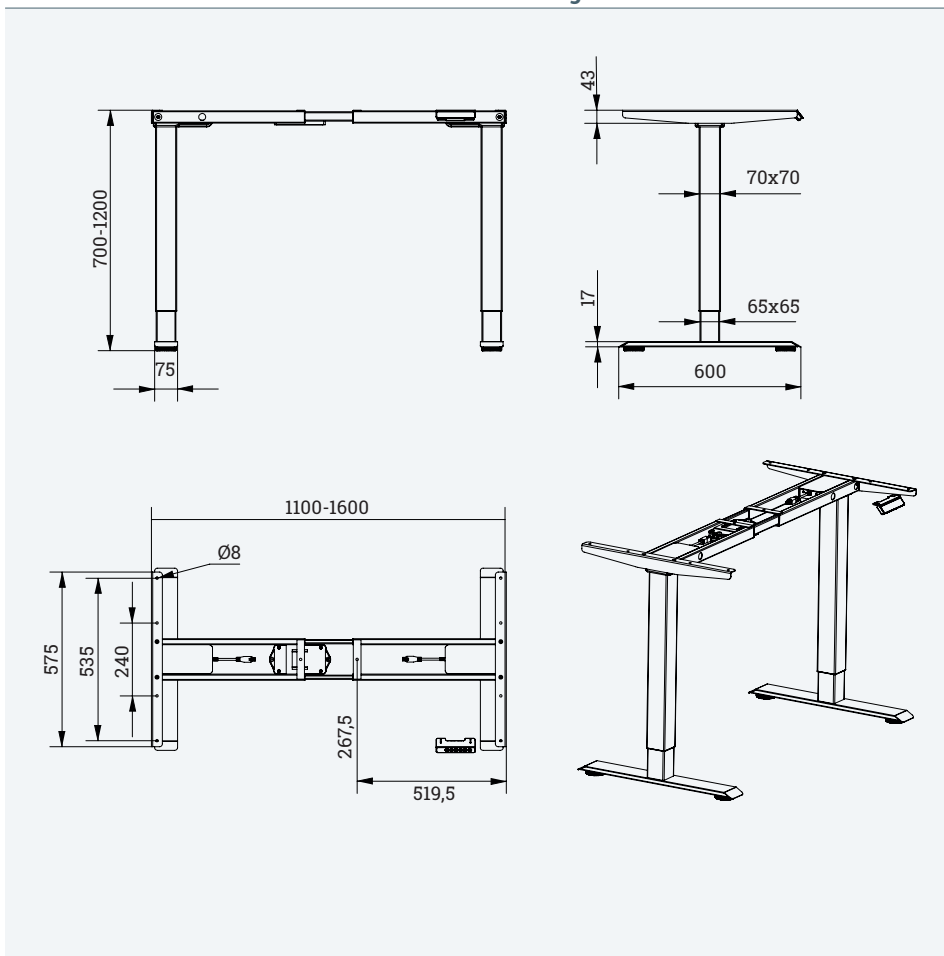

Article	Description	Colour	Item No.
E-SMART 2M2S	Electric height adjustable table frame, lifting columns: 70x70 mm, 700-1200 mm, 2 motors, 2 segments, 80 kg, 25 mm/s	RAL 9017, Traffic black	301 132039
		Aluminium	301 132025
		White	301 132032

# E-MORE 2M2S

Table frame, electric height adjustable

- ✓ 2 motors / rectangular 2-segment columns
- ✓ Five-language OLED control element with 4 memory slots and USB-C charging (18 W)
- ✓ Reminder function motivates the user to switch between sitting and standing Integrated
- ✓ Integrated double collision protection (sensitivity adjustable in 8 levels)
- ✓ 5 years warranty



## Details

<b>Motors</b>	2
<b>Lifting column segm.</b>	2
<b>Column cross-section</b>	60x90 mm
<b>Lifting range</b>	700-1200 mm
<b>Frame width</b>	1100-1800 mm
<b>Table top size min</b>	700x1100 mm
<b>Table top size max</b>	1000x2000 mm
<b>Load capacity</b>	120 kg
<b>Memory keys</b>	4
<b>Display</b>	OLED
<b>USB charging</b>	USB-C / 18 W
<b>Speed</b>	30 mm/s
<b>Double Anti collision function</b>	Overvoltage protection Gyroscope sensor
<b>Reminder function</b>	integrated
<b>Child lock</b>	integrated
<b>Sound level</b>	<50 dB
<b>Power consumpt. min</b>	0,1 W
<b>Power consumpt. max</b>	110 W
<b>Duty cycle</b>	max 2 min "on" / 18 min "off"



## Technical drawing

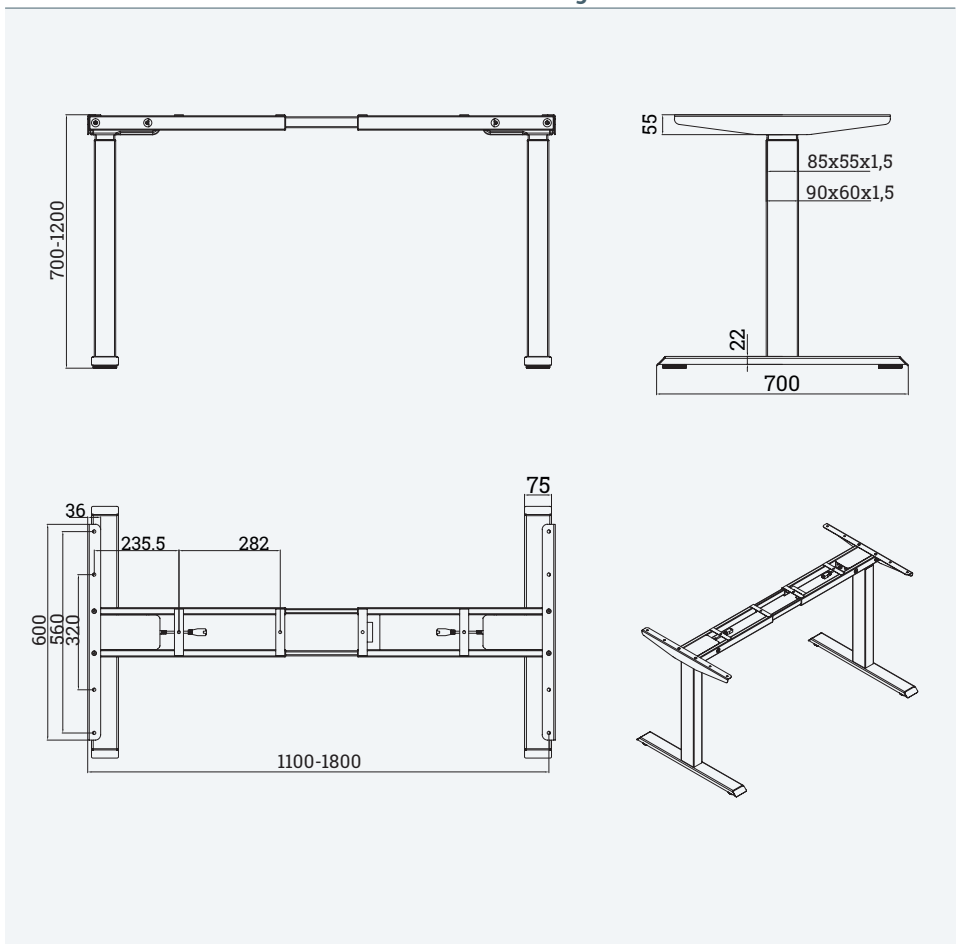

Article	Description	Colour	Item No.
E-MORE 2M2S	Electric height adjustable table frame, lifting columns: 90x60 mm, 700-1200 mm, 2 motors, 2 segments, 120 kg, 30 mm/s	RAL 9017, Traffic black	301 132060
		Aluminium	301 132046
		White	301 132053

# E-MORE 2M3S GS



Table frame, electric height adjustable, GS approved

- ✔ 2 motors / rectangular 3-segment columns
- ✔ Five-language OLED control element with 4 memory slots and USB-C charging (18 W)
- ✔ Reminder function motivates the user to switch between sitting and standing Integrated
- ✔ Integrated double collision protection (sensitivity adjustable in 8 levels)
- ✔ GS approved, 5 years warranty, 4 colours



www.tuv.com  
ID 1111282867

Applies to the table frame when used with a table top from the BMB range.

01 Table Frames

E-MORE 2M3S GS



## Details

<b>Motors</b>	2
<b>Lifting column segm.</b>	3
<b>Column cross-section</b>	60x90 mm
<b>Lifting range</b>	625-1275 mm
<b>Frame width</b>	1100-1800 mm
<b>Table top size min</b>	700x1100 mm
<b>Table top size max</b>	1000x2000 mm
<b>Load capacity</b>	120 kg
<b>Memory keys</b>	4
<b>Display</b>	OLED
<b>USB charging</b>	USB-C / 18 W
<b>Speed</b>	40 mm/s
<b>Double Anti collision function</b>	Overvoltage protection Gyroscope sensor
<b>Reminder function</b>	integrated
<b>Child lock</b>	integrated
<b>Sound level</b>	<50 dB
<b>Power consumpt. min</b>	0,1 W
<b>Power consumpt. max</b>	215 W
<b>Duty cycle</b>	max 2 min "on" / 18 min "off"
<b>Cascading options</b>	up to 12 columns



## Technical drawing

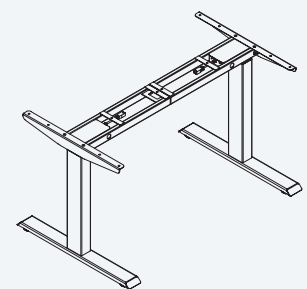
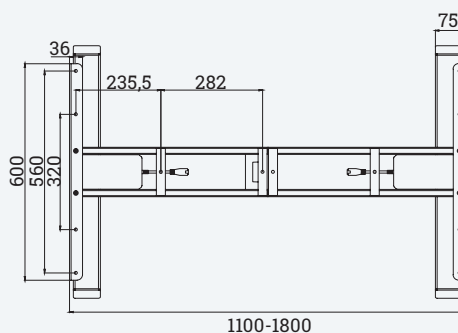
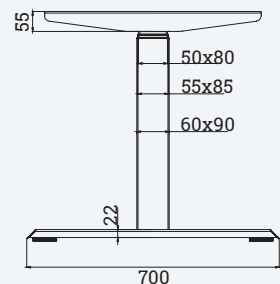
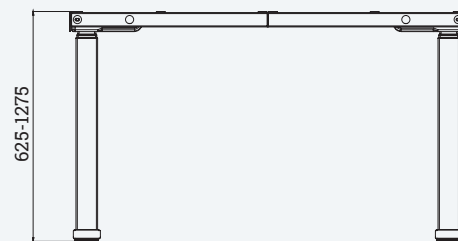

Article	Description	Colour	Item No.
<b>E-MORE 2M3S GS</b>	Electric height adjustable table frame, lifting columns: 60x90 mm, 625-1275 mm, 2 motors, 3 segments, 120 kg, 40 mm/s	RAL 9017, Traffic black	301 131920
		RAL 7016, Anthracite grey	301 131927
		Aluminium	301 132067
		White	301 132074



# E-MORE 2M3S GS QA



Table frame, electric height adjustable, Quick assembly, GS approved

- ✔ Very simple and quick installation / 2 motors / rectangular 3-segment columns
- ✔ Five-language OLED control element with 4 memory slots and USB-C charging (18 W)
- ✔ Reminder function motivates the user to switch between sitting and standing Integrated
- ✔ Integrated double collision protection (sensitivity adjustable in 8 levels)
- ✔ GS approved, 5 years warranty, 4 colours



www.tuv.com  
ID: 111282967

Applies to the table frame when used with a table top from the BMB range.

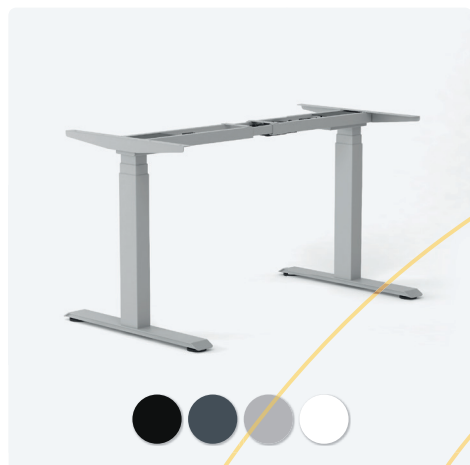

## Details

<b>Motors</b>	2
<b>Lifting column segm.</b>	3
<b>Column cross-section</b>	60x90 mm
<b>Lifting range</b>	625-1275 mm
<b>Frame width</b>	1110-1800 mm
<b>Table top size min</b>	700x1100 mm
<b>Table top size max</b>	1000x2000 mm
<b>Load capacity</b>	100 kg
<b>Memory keys</b>	4
<b>Display</b>	OLED
<b>USB charging</b>	USB-C / 18 W
<b>Speed</b>	40 mm/s
<b>Double anti collision function</b>	Overvoltage protection Gyroscope sensor
<b>Reminder function</b>	integrated
<b>Child lock</b>	integrated
<b>Sound level</b>	<50 dB
<b>Power consumpt. min</b>	0,1 W
<b>Power consumpt. max</b>	215 W
<b>Duty cycle</b>	max 2 min "on" / 18 min "off"
<b>Cascading options</b>	up to 12 columns

## Technical drawings

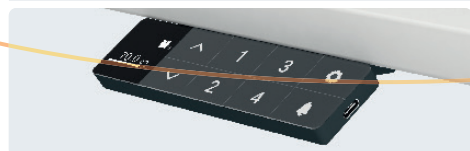
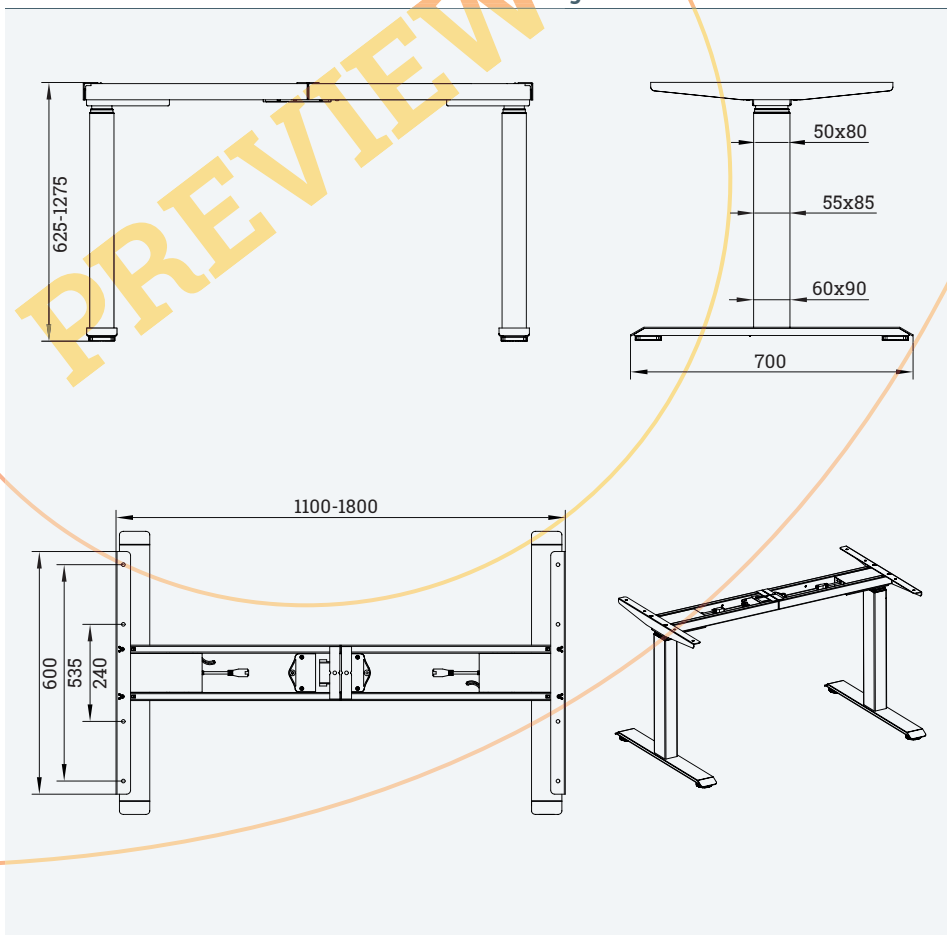

Article	Description	Colour	Item No.
E-MORE 2M3S GS QA	Electric height adjustable table frame, quick assembly, reverse lifting column: 50x80 mm, 2 motors, 3 segments, 100 kg, 40 mm/s	RAL 9017, Traffic black	301 132186
		RAL 7016, Anthracite grey	301 132193
		Aluminium	301 131934
		White	301 132179

# E-MORE 2M3S GS RD



Table frame, electric height adjustable with round lifting columns

- ✔ 2 motors / round 3-segment columns
- ✔ Five-language OLED control element with 4 memory slots and USB-C charging (18 W)
- ✔ Reminder function motivates the user to switch between sitting and standing Integrated
- ✔ Integrated double collision protection (sensitivity adjustable in 8 levels)
- ✔ GS approved, 5 years warranty, 4 colours



www.tuv.com  
ID 1111262967

Applies to the table frame when used with a table top from the BMB range.



## Details

Motors	2
Lifting column segm.	3
Column cross-section	Ø70 mm
Lifting range	625-1275 mm
Frame width	1100-1800 mm
Table top size min	700x1100 mm
Table top size max	1000x2000 mm
Load capacity	120 kg
Memory keys	4
Display	OLED
USB charging	USB-C / 18 W
Speed	40 mm/s
Double Anti collision function	Overvoltage protection Gyroscope sensor
Reminder function	integrated
Child lock	integrated
Sound level	<50 dB
Power consumpt. min	0,1 W
Power consumpt. max	215 W
Duty cycle	max 2 min "on" / 18 min "off"
Cascading options	up to 12 columns

## Technical drawings

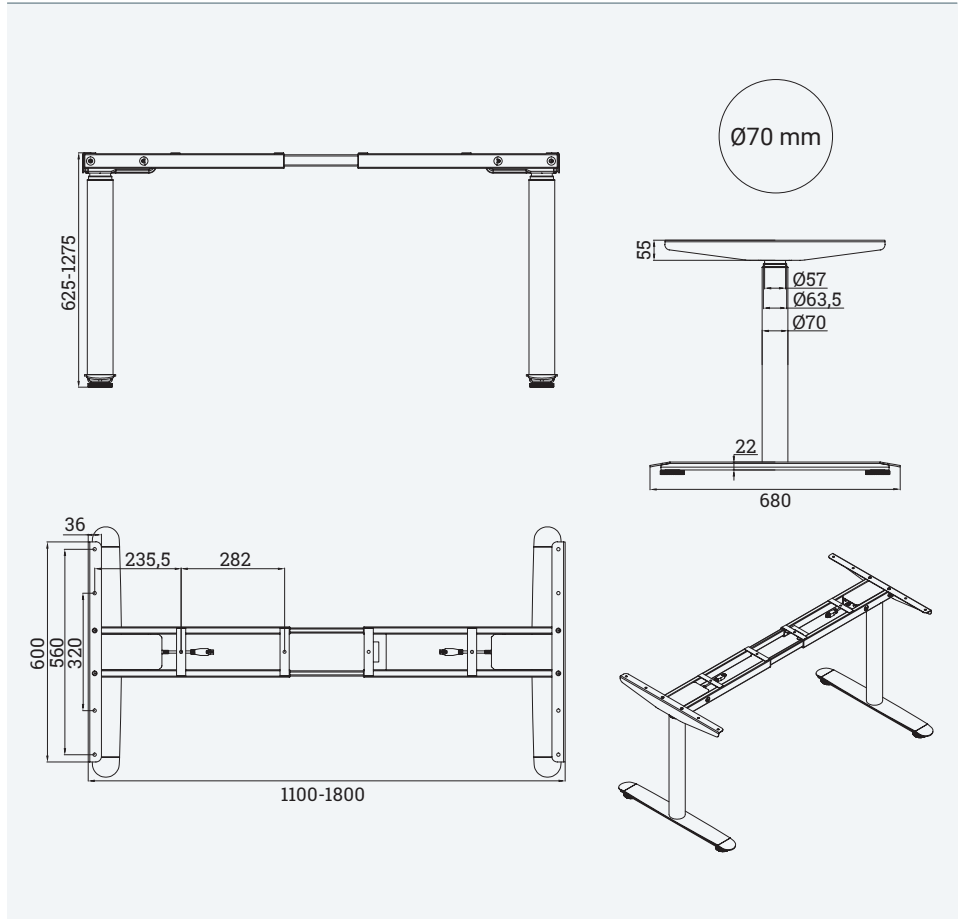

Article	Description	Colour	Item No.
E-MORE 2M3S GS RD	Electric height adjustable table frame, lifting column, Ø70 mm, 625-1275 mm, 2 motors, 3 segments, 120 kg, 40 mm/s	RAL 9017, Traffic black	301 132214
		RAL 7016, Anthracite grey	301 132221
		Aluminium	301 132200
		White	301 132207

# E-MORE 2M3S GS OV



Table frame, electric height adjustable with oval lifting columns

- ✓ 2 motors / oval 3-segment columns
- ✓ Five-language OLED control element with 4 memory slots and USB-C charging (18 W)
- ✓ Reminder function motivates the user to switch between sitting and standing Integrated
- ✓ Integrated double collision protection (sensitivity adjustable in 8 levels)
- ✓ GS approved, 5 years warranty, 4 colours



www.tuv.com  
ID 1111262967

Applies to the table frame when used with a table top from the BMB range.



## Details

Motors	2
Lifting column segm.	3
Column cross-section	58x91 mm (oval)
Lifting range	625-1275 mm
Frame width	1100-1800 mm
Table top size min	700x1100 mm
Table top size max	1000x2000 mm
Load capacity	120 kg
Memory keys	4
Display	OLED
USB charging	USB-C / 18 W
Speed	40 mm/s
Double Anti collision function	Overvoltage protection Gyroscope sensor
Reminder function	integrated
Child lock	integrated
Sound level	<50 dB
Power consumpt. min	0,1 W
Power consumpt. max	215 W
Duty cycle	max 2 min "on" / 18 min "off"
Cascading options	up to 12 columns

## Technical drawings

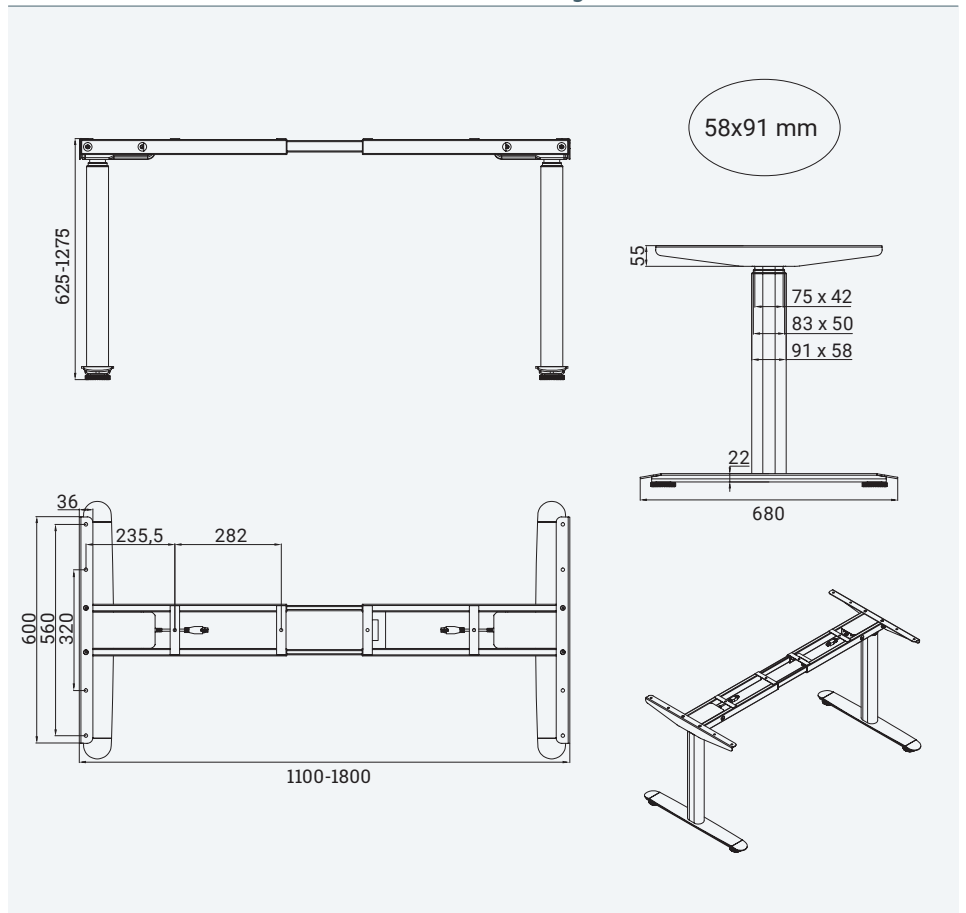

Article	Description	Colour	Item No.
E-MORE 2M3S GS OV	Electric height adjustable table frame, oval lifting columns: 58x91 mm, 625-1275 mm, 2 motors, 3 segments, 120 kg, 40 mm/s	RAL 9017, Traffic black	301 132242
		RAL 7016, Anthracite grey	301 132249
		Aluminium	301 132228
		White	301 132235



# E-CORNER 3M3S



Corner table frame, electrical height adjustable with two mounting versions

- ✔ Corner table frame with two mounting options: A-90° and B-Flex (60° to 180° continuously adjustable)
- ✔ Five-language OLED control element with 4 memory slots and USB-C charging (18 W)
- ✔ Reminder function motivates the user to switch between sitting and standing Integrated
- ✔ Integrated double collision protection (sensitivity adjustable in 8 levels)
- ✔ GS approved, 5 years warranty, 4 colours

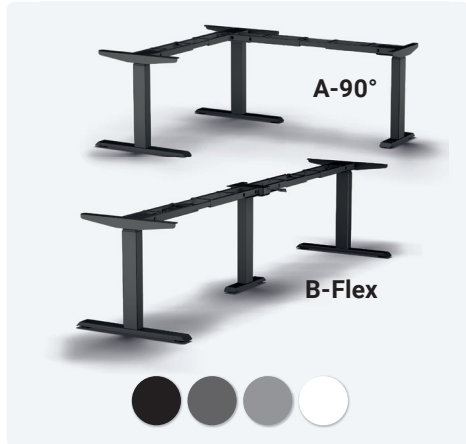
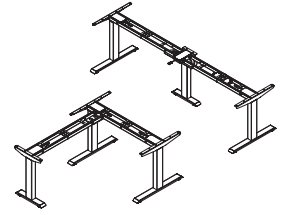

## Details

<b>Motors</b>	3
<b>Lifting column segm.</b>	3
<b>Column cross-section</b>	60x90 mm
<b>Lifting range</b>	625-1275 mm
<b>Frame width X</b>	1100-1800 mm
<b>Table top size min 1</b>	700x1100 mm
<b>Table top size min 2</b>	400x850 mm
<b>Table top size min 3</b>	700x2310 mm
<b>Table top size max 1</b>	1000x2000 mm
<b>Table top size max 2</b>	1000x1800 mm
<b>Table top size max 3</b>	1000x4000 mm
<b>Load capacity</b>	180 kg
<b>Memory keys</b>	4
<b>Display</b>	OLED
<b>USB charging</b>	USB-C / 18 W
<b>Speed</b>	40 mm/s
<b>Double Anti collision function</b>	Overvoltage protection Gyroscope sensor
<b>Reminder function</b>	integrated
<b>Child lock</b>	integrated
<b>Sound level</b>	<50 dB
<b>Power consumpt. min</b>	0,1 W
<b>Power consumpt. max</b>	320 W
<b>Duty cycle</b>	max 2 min "on" / 18 min "off"
<b>Cascading options</b>	up to 12 columns

## Mounting version: A-90°

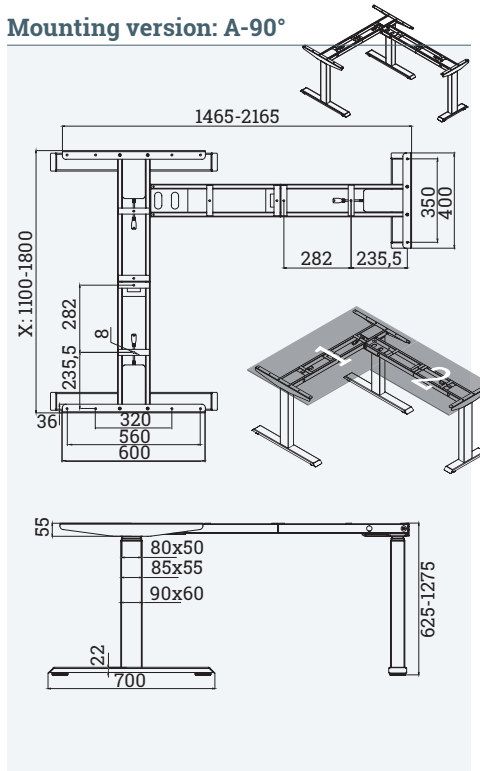

## Mounting version: B-Flex 60-180°

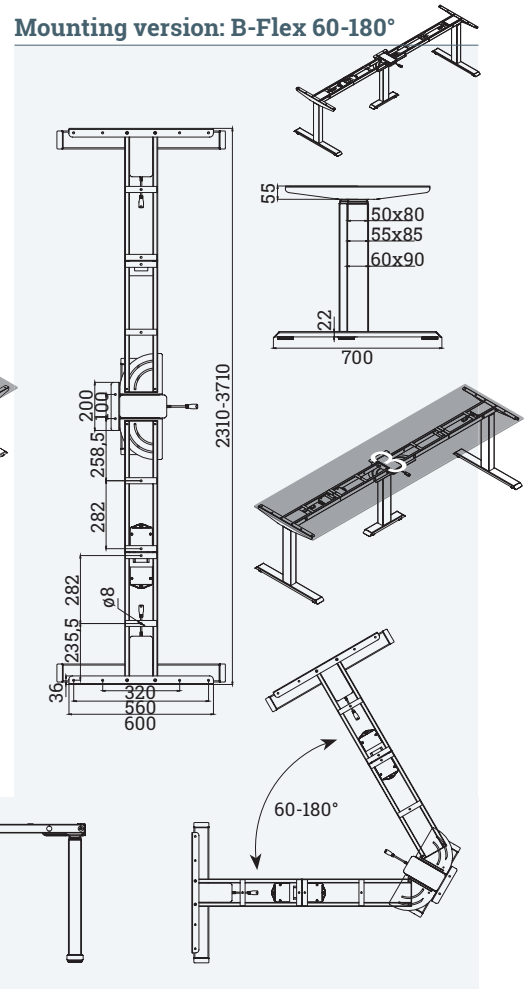

Article	Description	Colour	Item No.
E-CORNER 3M3S	Electric height adjustable corner table frame, lifting columns: 90x60 mm, 625-1275 mm, 3 motors, 3 segments, 180 kg, 40 mm/s, with two mounting versions	RAL 9017, Traffic black	301 132095
		RAL 7016, Anthracite grey	301 132102
		Aluminium	301 132081
		White	301 132088

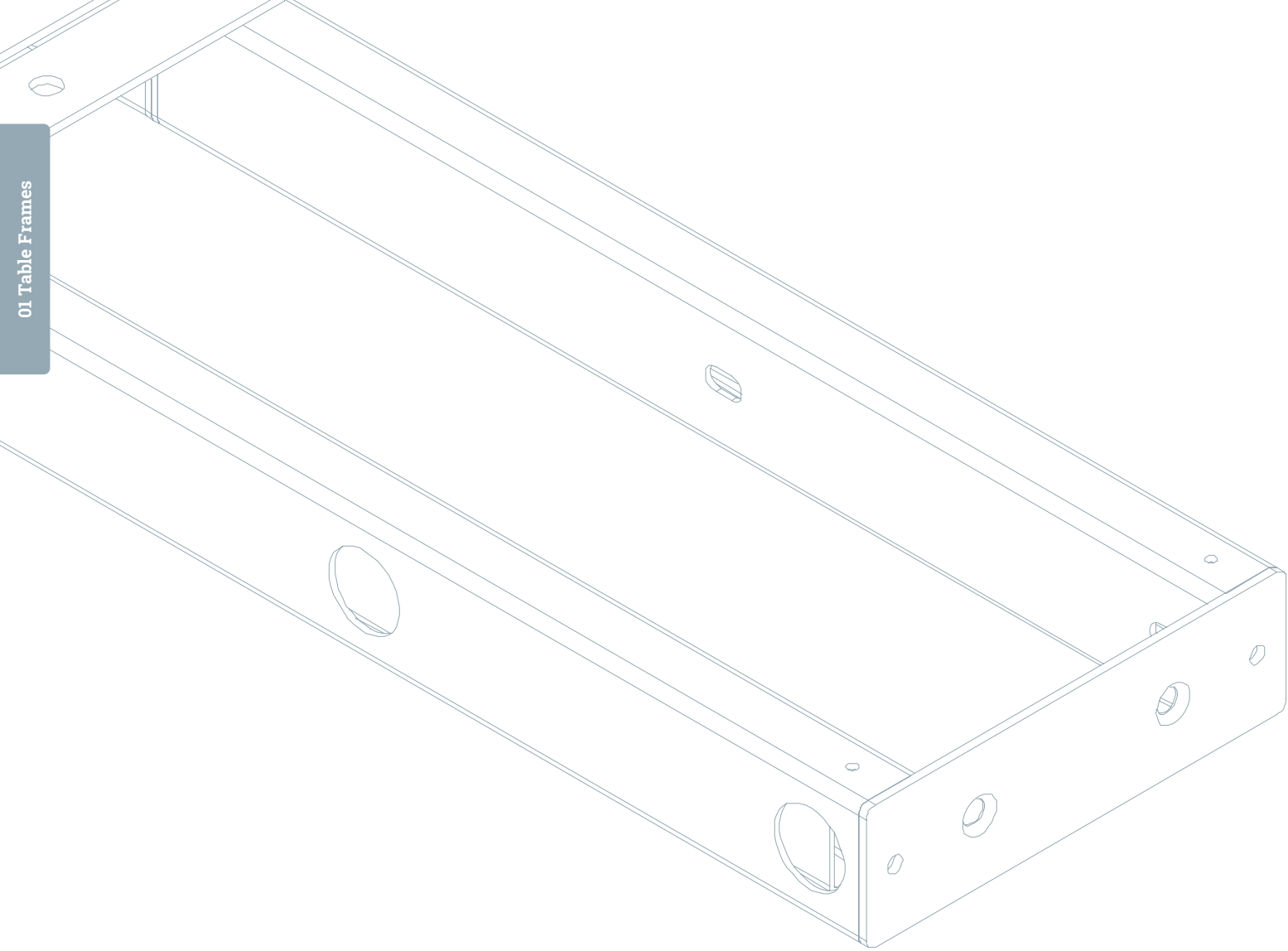

# Accessories for Electric Height Adjustable Table frames

Cable tray for double crossbar table frames

- ✔ Optional accessory for cable tray
- ✔ 4 colours

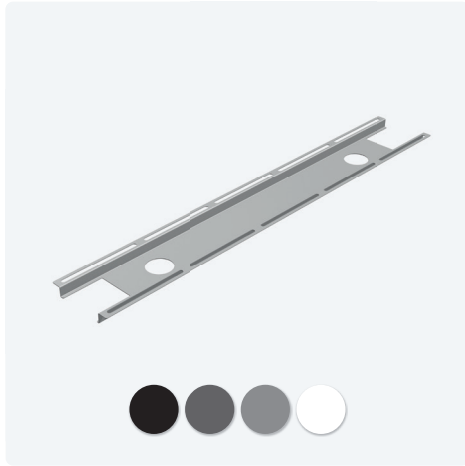

### Technical drawings

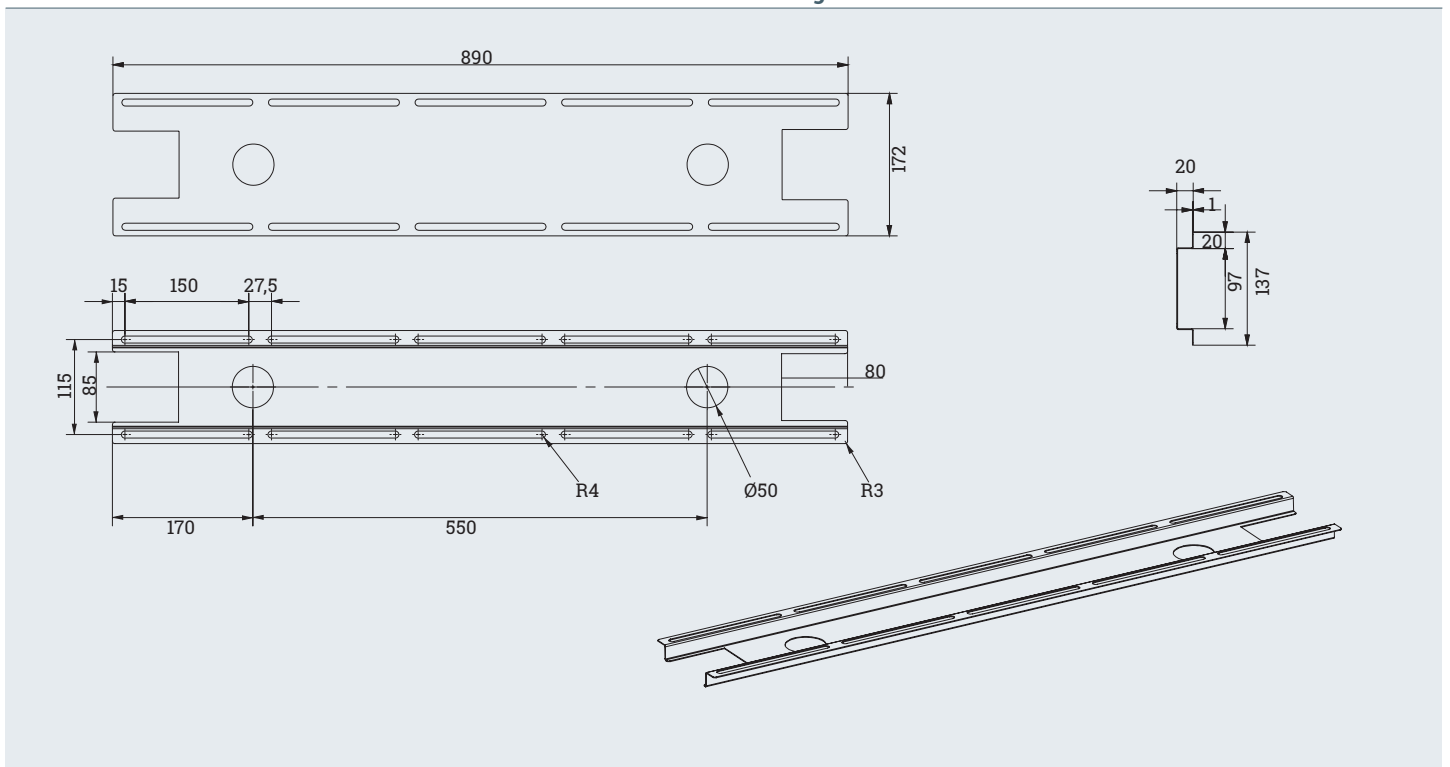

Article	Description	Colour	Item No.
E-PLUS BOXIT	Cable tray for E-SMART 2M2S, E-MORE 2M2S, E-MORE 2M3S GS, E-MORE 2M3S GS QA, E-MORE 2M3S GS RD, E-MORE 2M3S GS OV, E-CORNER 3M3S, E-SOLID 300/400, E-POINT 4M3S, E-BENCH 4M3S	RAL 9017, Traffic black	302 132144
		RAL 7016, Anthracite grey	302 132151
		Aluminium	302 132130
		White	302 132137

Optional beam for longer table tops

- ✔ Allows table top sizes with a width of 1800-2400 mm
- ✔ Ideal for use in large workplaces
- ✔ Enables retrofitting - a subsequent extension of the basic product

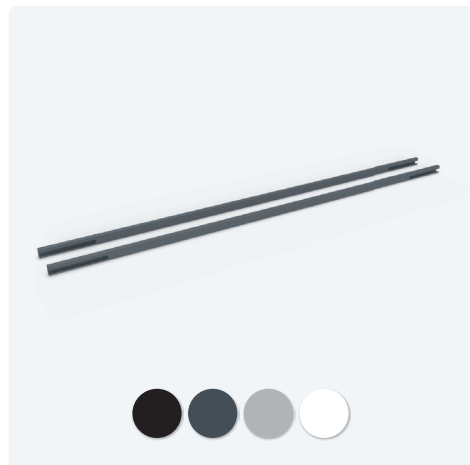

### Technical drawings

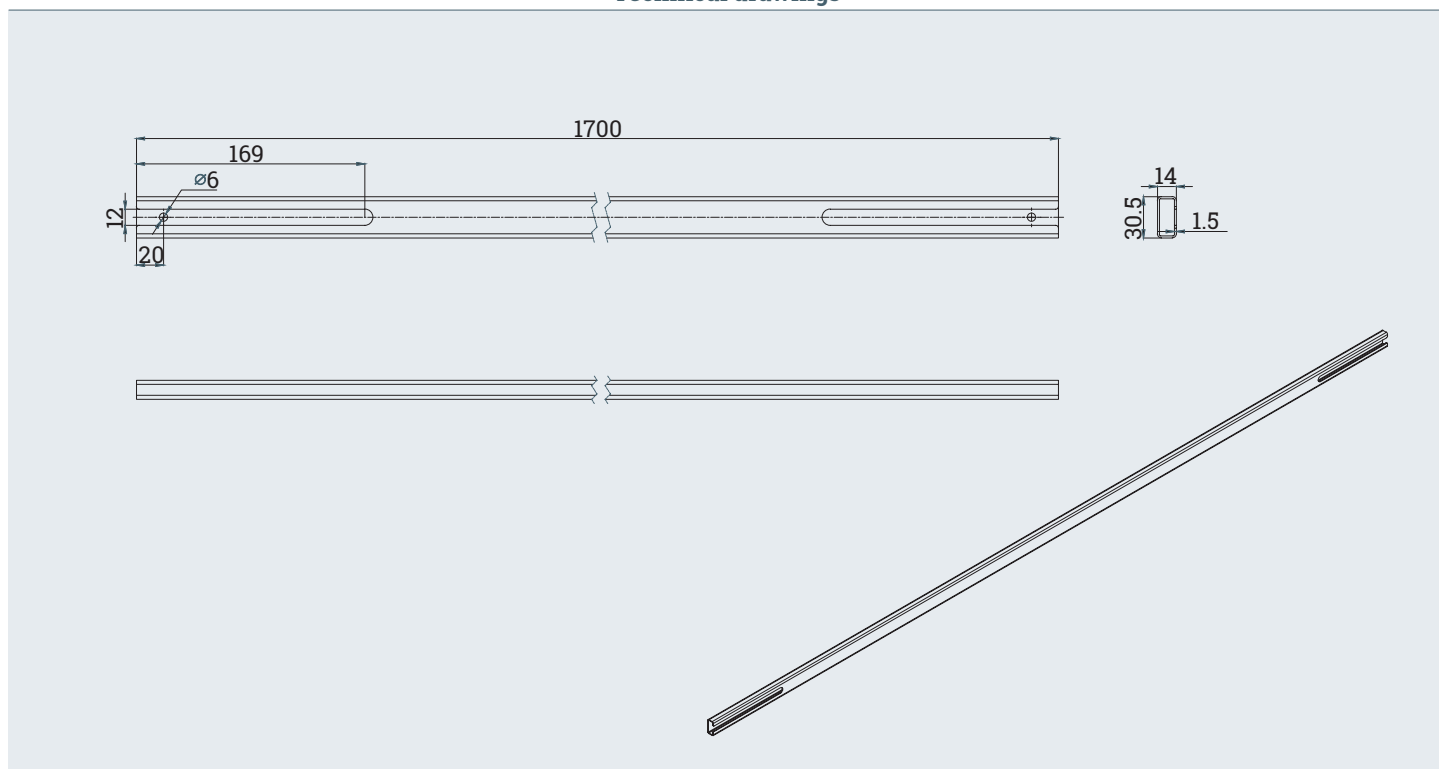

Article	Description	Colour	Item No.
E-PLUS L	Beam extension, frame width up to 2400 mm, for E-SMART 2M2S, E-MORE 2M2S, E-MORE 2M3S GS, E-MORE 2M3S GS QA, E-MORE 2M3S GS RD, E-MORE 2M3S GS OV, E-CORNER 3M3S, E-SOLID 300/450	RAL 9017, Traffic black	302 132487
		RAL 7016, Anthracite grey	302 132494
		Aluminium	302 132473
		White	302 132480

## Shorter Rails for electric height adjustable desk frames

- ✔ Allows side beams to be reduced to a width of 700-1100 mm
- ✔ Enables retrofitting - a subsequent extension of the basic product



### Technical drawings

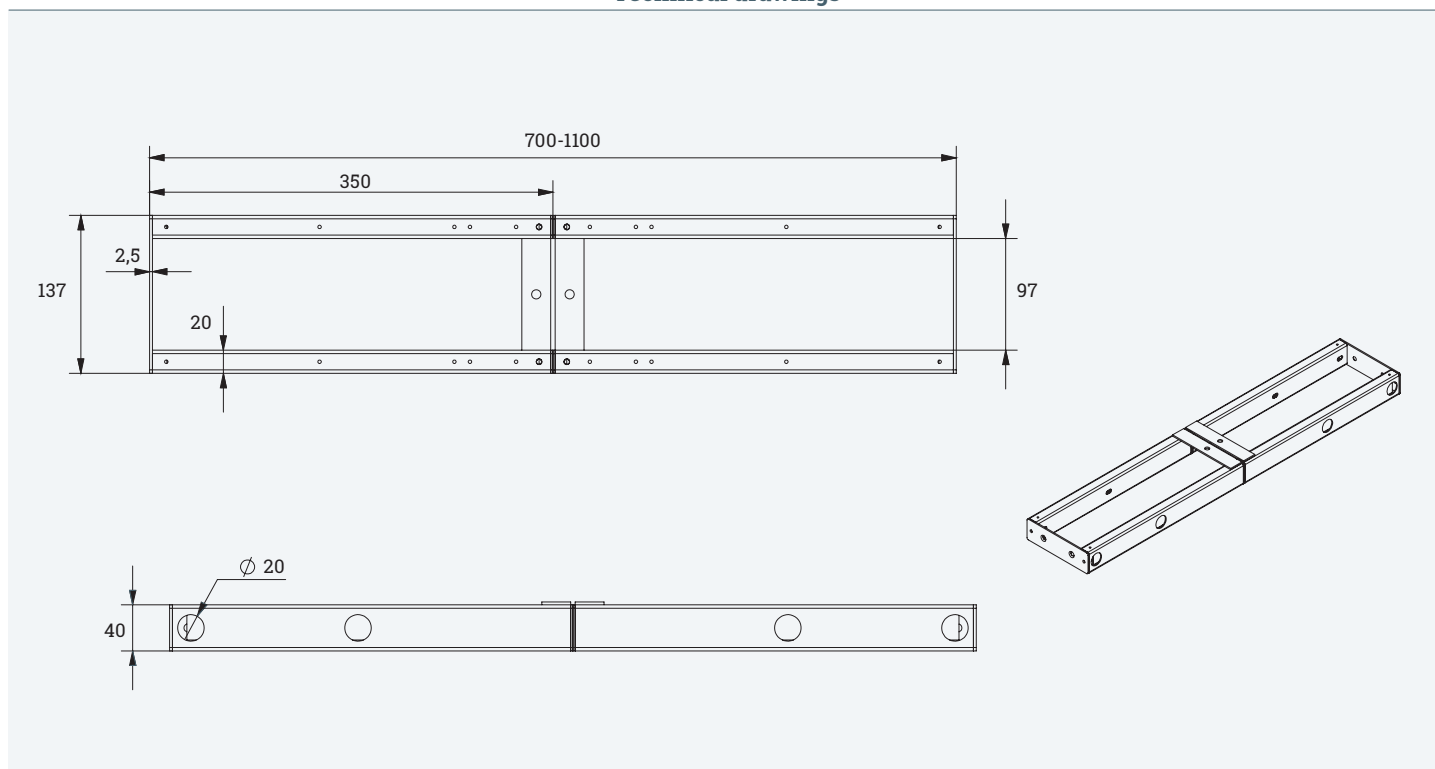

Article	Description	Colour	Item No.
E-PLUS S	Shorter rails for electric height adjustable desk frames, frame length 700-1100 mm	RAL 9017, Traffic black	302 132403
		RAL 7016, Anthracite grey	302 132410
		Aluminium	302 132389
		White	302 132396



# E-PLUS CL / CR

Side extension kit: Side bracket and table foot for frame extension

- ✔ Enables curved table tops by extending the frame left/right
- ✔ Enables retrofitting - a subsequent extension of the basic product
- ✔ 4 colours



## Technical drawings

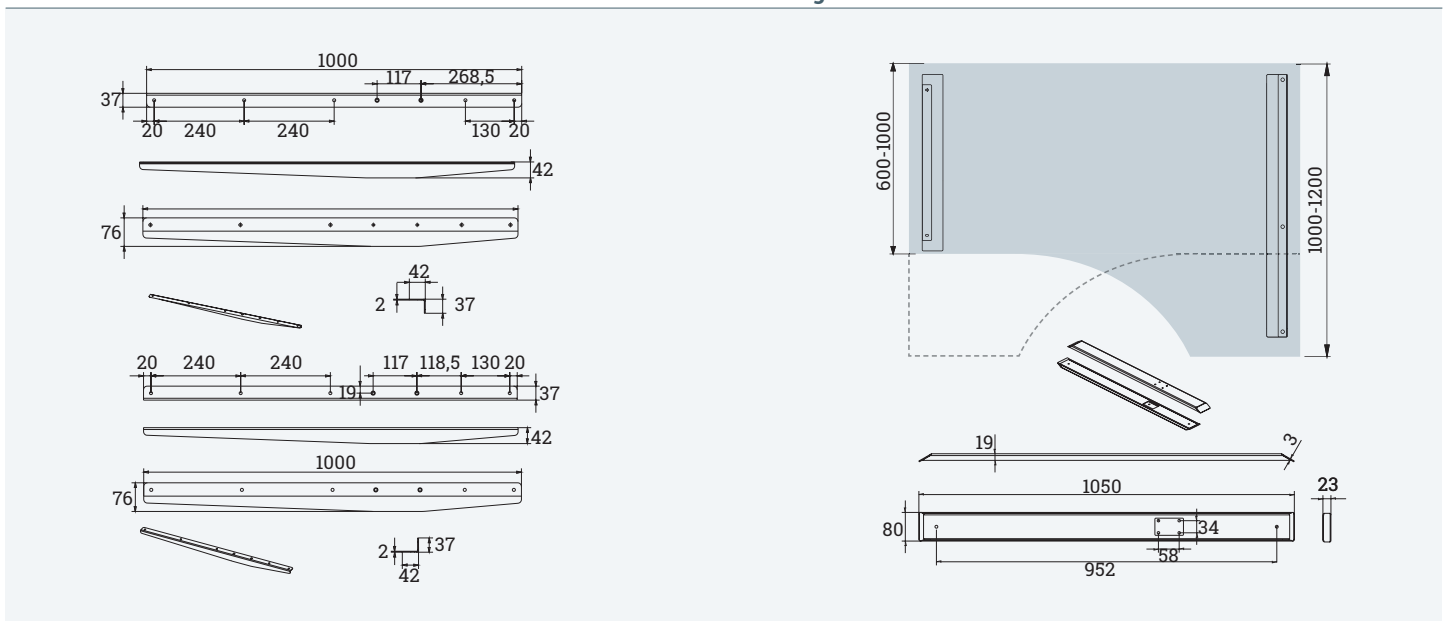

Article	left/right	Description	Colour	Item No.
<b>E-PLUS CL</b>	left	Side extension 1000 mm (longer foot and longer support bracket)	RAL 9017, Traffic black	302 132431
			RAL 7016, Anthracite grey	302 132438
			Aluminium	302 132865
			White	302 132424
<b>E-PLUS CR</b>	right	Side extension 1000 mm (longer foot and longer support bracket)	RAL 9017, Traffic black	302 132851
			RAL 7016, Anthracite grey	302 132844
			Aluminium	302 132417
			White	302 132858

# E-PLUS T2C

Conversion kit for C-type feet and brackets

- Optional accessory for E-MORE 2M2S, E-MORE 2M3S GS
- Conversion set to convert existing table models with T-frame into C-models
- Enables retrofitting to update existing frames
- 4 colours

01 Table Frames

E-PLUS T2C

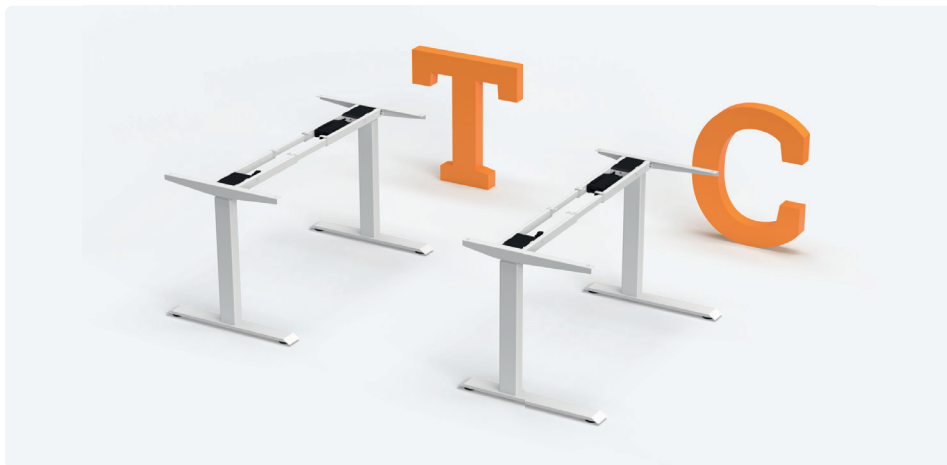

## Technical drawings

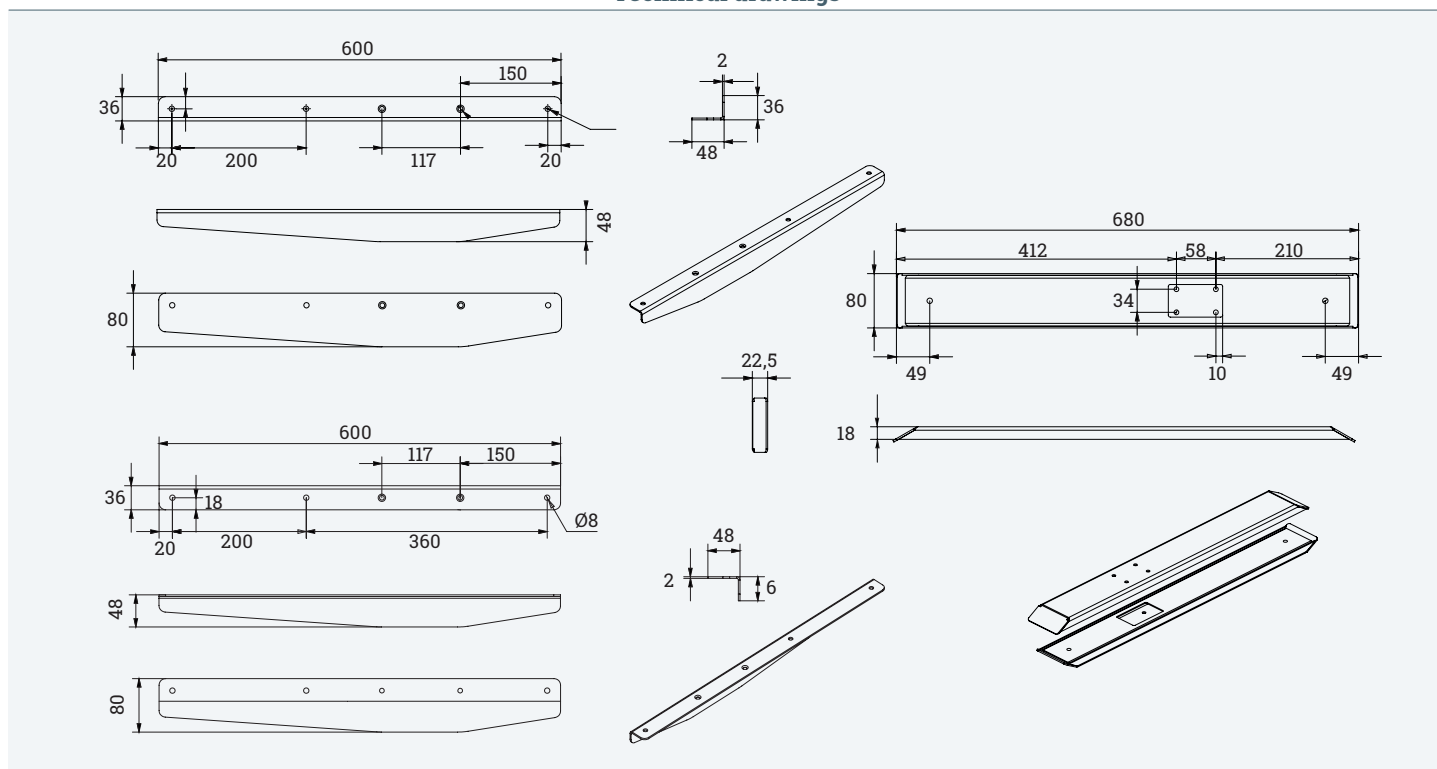

Article	Description	Colour	Item No.
<b>E-PLUS T2C</b>	Conversion kit consisting of 2 table foots and 2 side brackets (type C)	RAL 9017, Traffic black	302 132459
		RAL 7016, Anthracite black	302 132466
		Aluminium	302 132445
		White	302 132452

## E-CORNER 3M3S Lifting column

- ✓ 1 motor / rectangular 3-segment column
- ✓ Optional centre lifting column for extending the E-CORNER 3M3S
- ✓ Customised constellations possible
- ✓ With LED handset

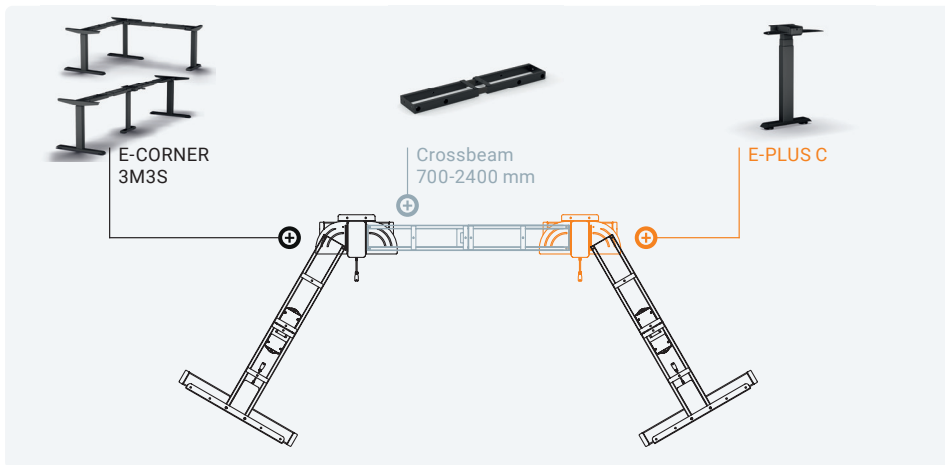

### Details

Motors	1
Lifting column segm.	3
Column cross-section	60x90 mm
Lifting range	625-1275 mm
Speed	40 mm/s
Sound level	<50 dB
Cascading options	up to 12 columns

### Technical drawings



E-CORNER 3M3S

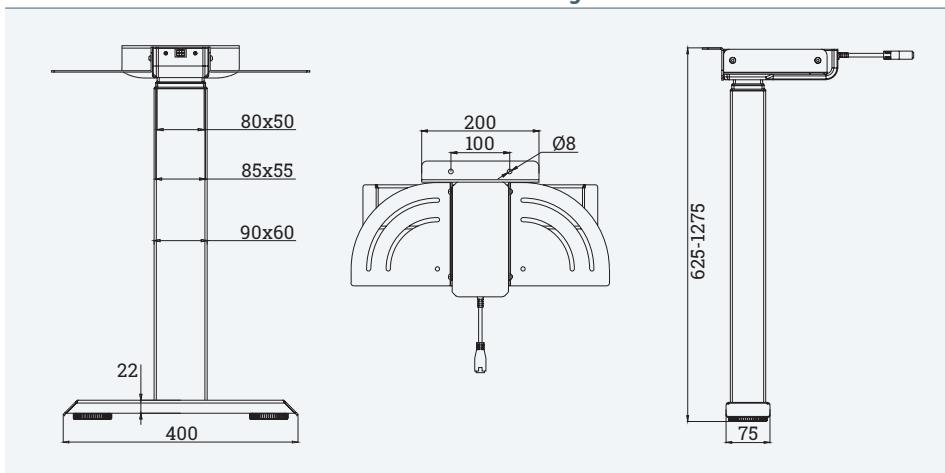

Article	Description	Colour	Item No.
<b>E-PLUS C</b>	Optional centre lifting column, 40 mm/s, 60x90 mm	RAL 9017, Traffic black	302 132676
		RAL 7016, Anthracite grey	302 132683
		Aluminium	302 132662
		White	302 132669
<b>E-PLUS S</b>	Shorter rail: 700-1100 mm	RAL 9017, Traffic black	302 132403
		RAL 7016, Anthracite grey	302 132410
		Aluminium	302 132389
		White	302 132396
<b>E-PLUS C 1800</b>	Optional crossbeam 1800 mm, For connecting multiple columns using E-PLUS C	RAL 9017, Traffic black	302 133747
		RAL 7016, Anthracite grey	302 133754
		Aluminium	302 133733
		White	302 133740
<b>E-PLUS C 2400</b>	Optional crossbeam 2400 mm, For connecting multiple columns using E-PLUS C	RAL 9017, Traffic black	302 133782
		RAL 7016, Anthracite grey	302 133768
		Aluminium	302 133761
		White	302 133775