

E-MONO 1M3S

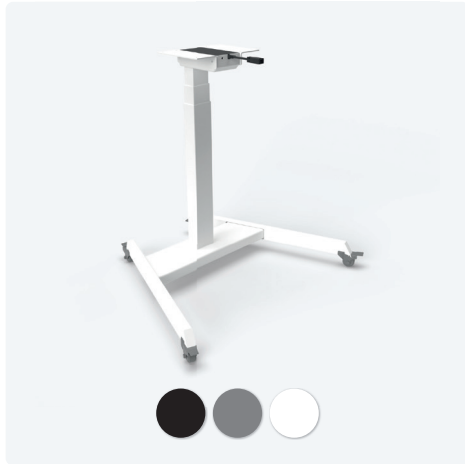

Electric height adjustable single column table frame, movable

- ✓ Movable
- ✓ Battery Pack available on demand
- ✓ 3-part lifting column
- ✓ 3 memory keys
- ✓ Anti collision function



Details

Motors	1
Lifting column segm.	3
Column cross-section	70x70 mm
Lifting range	745-1245 mm
Table top size min	400x400 mm
Table top size max	600x1000 mm
Load capacity	80 kg
Memory keys	3
USB charging	USB-A / 18 W
Speed	30 mm/s
Anti collision function	integrated (8 level)
Reminder function	integrated
Child lock	integrated
Sound level	<50 dB
Power consumpt. min	0,5 W
Power consumpt. max	38 W
Cascading options	up to two columns



Technical drawings

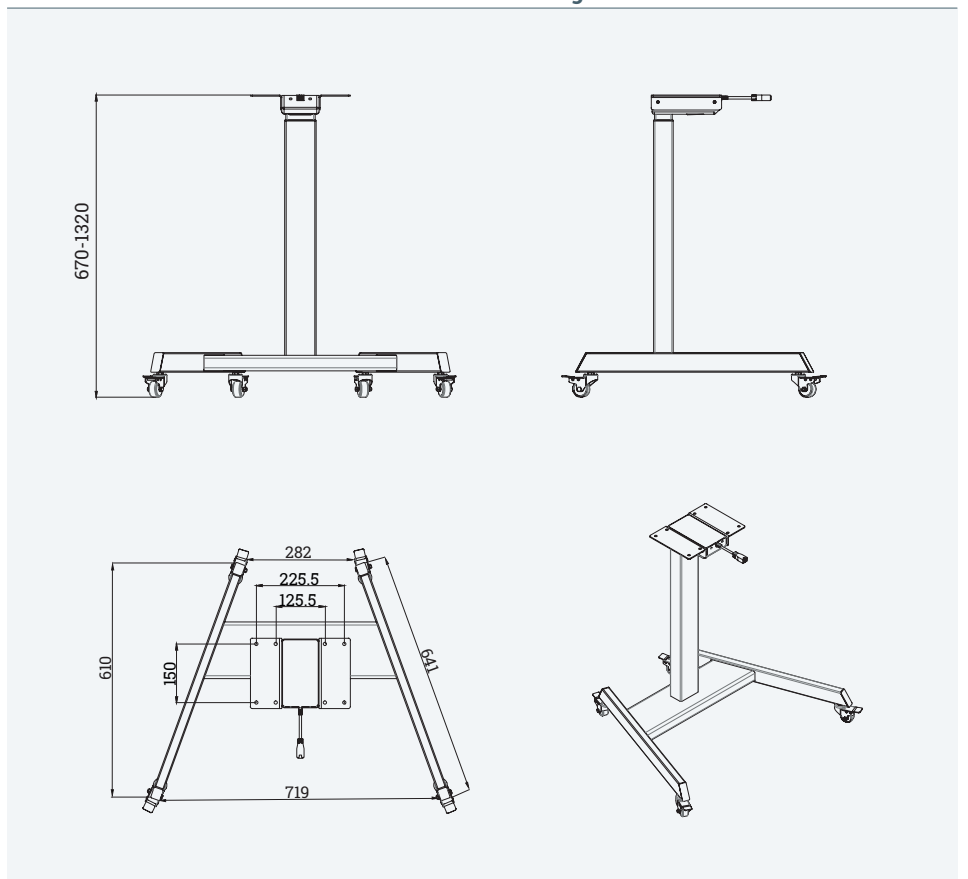

Article	Description	Colour	Item No.
E-MONO 1M3S	Electric height adjustable single column table frame, 1 Motor, 3-segments	RAL 9017, Traffic black	301 124108
		RAL 9006, White aluminium	301 123849
		RAL 9010, Pure white	301 124115



E-MURO 1M2S



Electric height adjustable single column folding table frame wall mounted

- ✔ Wall mounted and foldable
- ✔ 1 motor / 2 segments
- ✔ 3 memory keys
- ✔ Anti collision function



Details

Motors	1
Lifting column segm.	2
Column cross-section	70x70 mm
Lifting range	745-1245 mm
Table top size min	400x400 mm
Table top size max	600x1000 mm
Load capacity	80 kg
Memory keys	3
USB charging	USB-A / 18 W
Speed	20 mm/s
Anti collision function	integrated (8 level)
Reminder function	integrated
Child lock	integrated
Sound level	<50 dB
Power consumpt. min	0,5 W
Power consumpt. max	38 W
Cascading options	up to two columns

Technical drawings

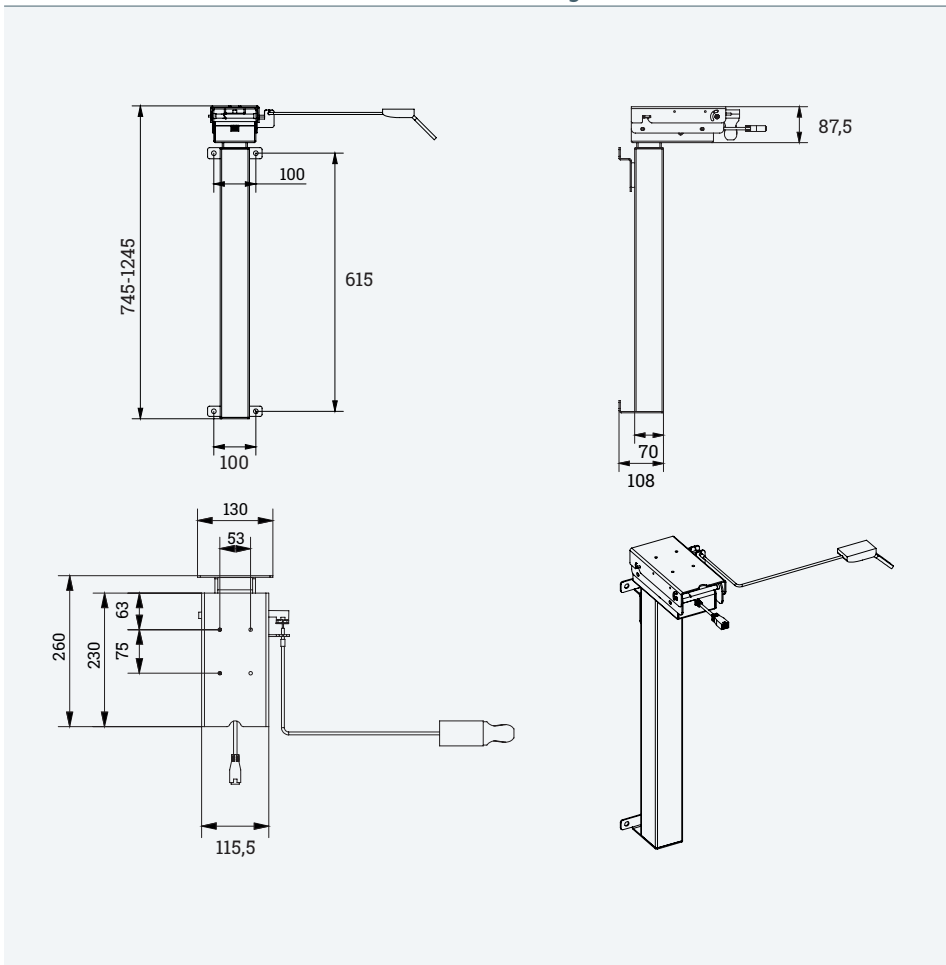

Article	Description	Colour	Item No.
E-MURO 1M2S	Electric height adjustable desk, wall mounted, foldable, 1 motor, 2 segments, 20 mm/s	RAL 9017, Traffic black	301 129043
		RAL 9010, Pure white	301 129057

